

General

Model: centrifugal ventilator.
The robust ventilator body is made of die-cast aluminium alloy and is coated. Asynchronous motor according IEC-standard, fully closed and fitted with long-life ball bearings. Position of outlet changeable and inlet provided with protection grid.

Application

Suitable for transport of clean and dusty gasses without abrasive particals and with a temperature limited to 80°C.

Algemeen

Type: centrifugaalventilator.
Het robuuste ventilatorhuis is gemaakt uit gietaluminium en gecoat. De asynchrone motor voldoet aan de IEC-norm, is geheel gesloten en voorzien van duurzame kogellagers. Positie uitblaasopening te wijzigen en inlaat voorzien van rooster.

Toepassing

Inzetbaar voor transport van schone en vervuilde gassen, zonder schurende stoffen, met een maximum temperatuur van 80°C.



Technical data

Power	Vermogen	1.5	kW
Voltage 1~	Spanning 1~	230	V
3~	3~	230/400	V
Current 1~	Stroom 1~	12.4	A
3~	3~	6.3/3.5	A
Frequency	Frequentie	50	Hz
Revolutions	Toerental	2800	/min
Protection class	Bescherming	IP 54	
Noise level	Geluidsniveau	60	dB
Weight	Gewicht	33	kg
Positions	Posities	1,2,3,4,5,6	

Technische gegevens

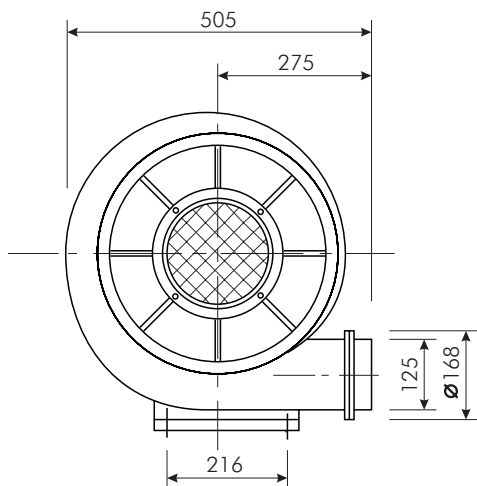
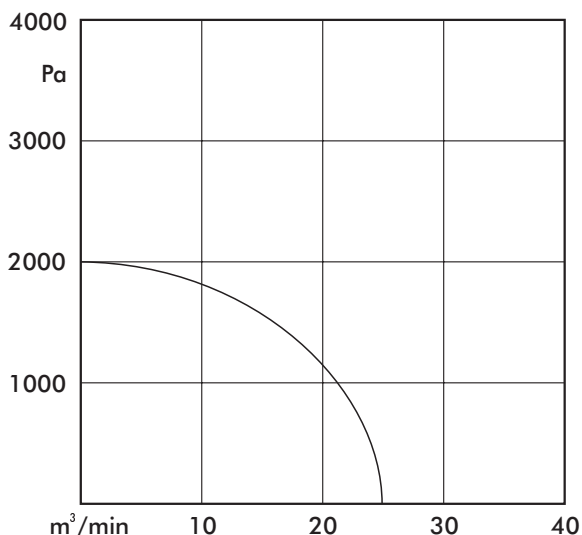

Dimensions in mm

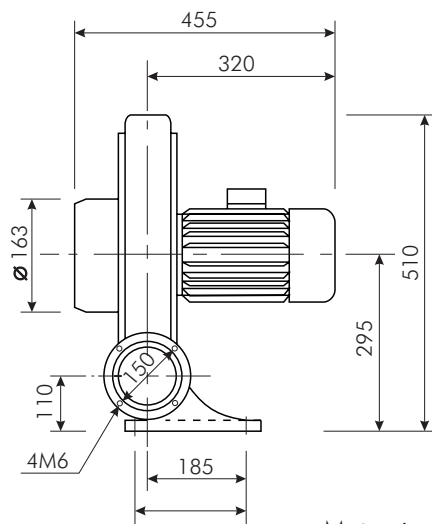

Maten in mm